

# EMC and installations

**B. Jover - EMC Expert**



**Merlin Gerin**

**Square D**

**Telemecanique**

**Schneider**  
 **Electric**



# Contents

- **EMC definition**
- **How to define an EMC problem**
- **Disturbance levels**
- **The electromagnetic phenomena**
- **General principles of EMC protection**
- **Earthing system and equipotential bonding**
- **Earthing systems and EMC**
- **Busways**
- **Cabling Management System (raceways)**
- **How to connect the screen of a cable**
- **Data cables and connectors**
- **Surge Protective Devices**
- **European Standardisation**
- **EMC Expertise Services**



# Electromagnetic Compatibility (EMC):

## ■ Definition:

A device or system's capability to operate in its electromagnetic environment in a satisfactory way, without producing electromagnetic disturbances itself.

- EMC is taken into account from the beginning of design phase to the manufacturing of electric or electronic equipment. It must also be considered when the equipment is implemented. All the skills are concerned, from building architects to installers, without forgetting network study engineers and contractors. The aim is to avoid that equipment are disturbed and/or emit disturbances.



# How to define an EMC problem



■ defines the origin of emitted disturbances

- Radiated
- Conducted

■ represents disturbance transmission means

- Common impedance
- Capacitive
- Inductive
- Field to Cable
- Common Mode Loop

■ all the equipment liable to be disturbed

- Any electrical and electronic equipment



# Disturbance levels

Disturbance level



**Operating fault**

Susceptibility level

**Margin**

Immunity level

Compatibility level

**Normal operation**

- Electromagnetic disturbance
  - Electromagnetic phenomenon liable to create operating problems on a mechanism, device or system, or have an unfavourable effect on living or inert matter.
  
- Electromagnetic compatibility level
  - Maximum specified electromagnetic disturbance level to which a device is expected to be subjected in particular operating conditions.
  
- Immunity level
  - Maximum level of electromagnetic disturbance at which the device remains able to operate with the required level of quality.
  
- Susceptibility level
  - Level from which equipment or system are disturbed.



# The electromagnetic phenomena

## Low Frequency (< 1 MHz)

- **Conducted: the disturbances flow through the cables**
  - flicker
  - voltage deeps
  - power line transmission
  - unbalance voltages
  - frequency variations
  - induced voltages
  - breakdown voltage
  - overvoltages (tripping, lightning waves))
  - harmonics
  
- **Radiated: The disturbances flow through the air**
  - magnetic field (transformer, induction furnace, courant fault, railways feeders, etc.)
  - electric field (high voltage lines, railways feeders)
  - lightning strikes



# The electromagnetic phenomena High Frequency ( $\geq 1$ MHz)

- **Conducted: the disturbances flow through the cables**
  - induced permanent voltages or currents
  - unidirectional transients
  - oscillatory transients
  
- **Radiated: The disturbances flow through the air**
  - electromagnetic fields (broadcast and telecommunication emitters, radar, etc.)
  - arcing and spark spectrum (breakage arc, lightning arc, catenary/pantograph, switching contact, etc.)
  - electrostatic discharge
  - HEMP (High Altitude Nuclear Electromagnetic Pulse)



# General principles of EMC protection

- **The following factors contribute to EMC protection:**
  - improvement of equipment immunity,
  - reduction of disturbances at the source,
  - coupling factors (cabling).
  
- **To achieve satisfactory operating quality, the following points are required:**
  - a single equipotential earth system used as the site's potential reference,
  - a power distribution with a TN-S (or TT) earthing system,
  - separation of different kinds of cables (power, auxiliary, data, measures),
  - use of metallic cable management systems (cable trays),
  - use of screened cables for data and measure,
  - a power supply protection (filtering, overvoltage protection),
  - equipment and installation protection against the indirect effects of lightning,



# Earthing system and equipotential bonding

- **The earthing system ensures the following, in all conditions:**
  - safety of people,
  - protection of equipment,
  - potential reference for the electrical distribution source.
  
- **Equipotential bonding reduces common impedance between equipment and reduces ground loop surface areas.**
  - Equipotential bonding consists of interconnecting all the exposed metallic parts (raceways, pipes, building structures, raised floors, chassis, cubicles, etc.)
  - It must be meshed in the 3 dimensions
  - The smaller the mesh, the more effective the system is.



# Earthing structures

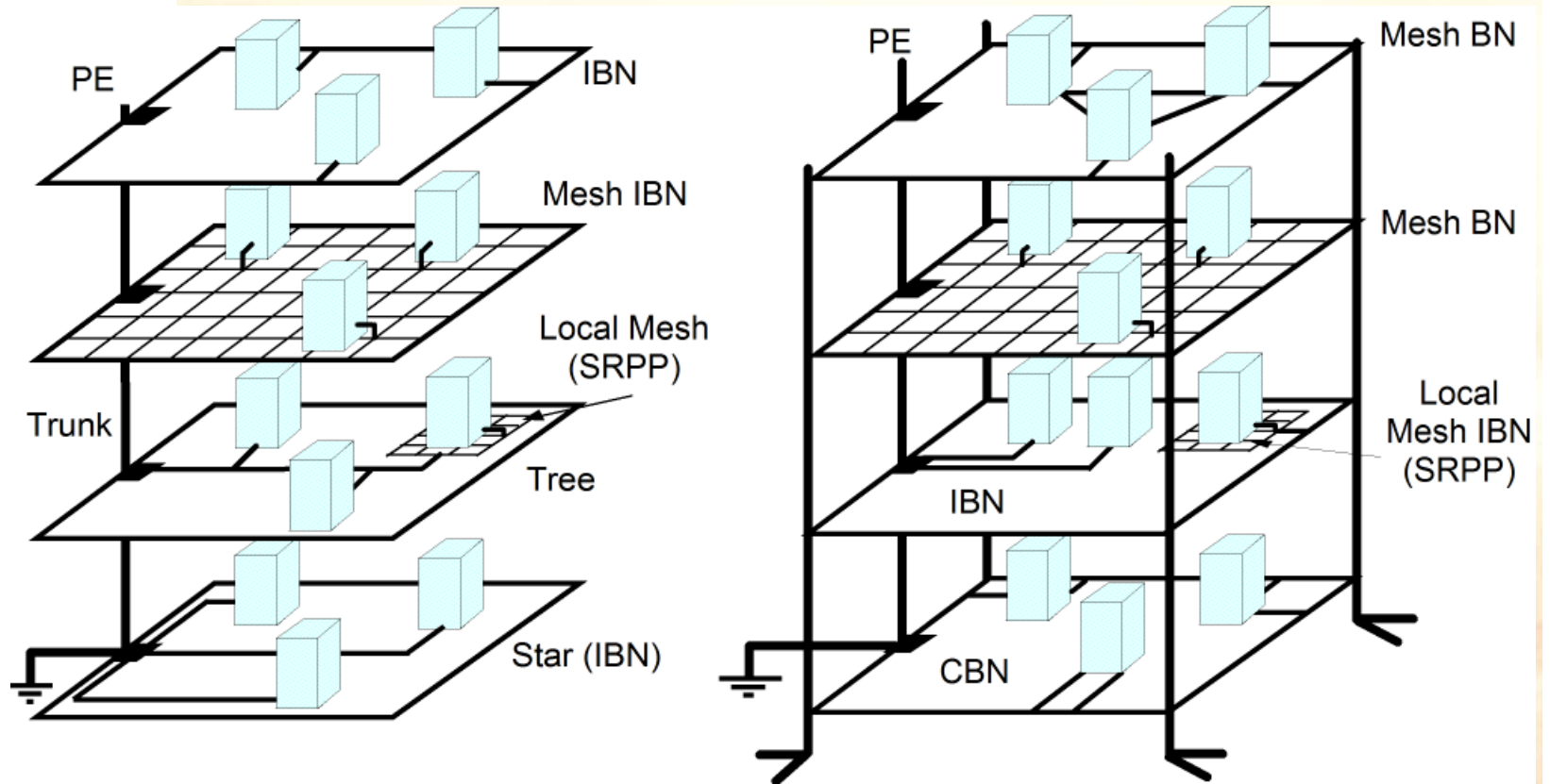

# Earthing systems and EMC

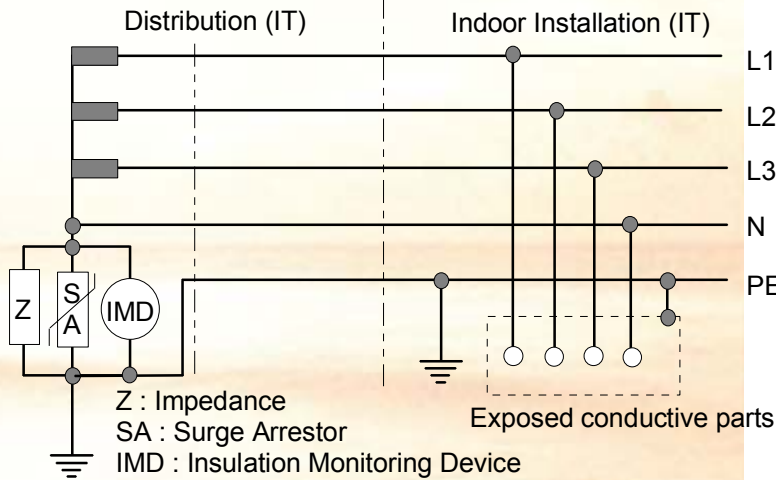
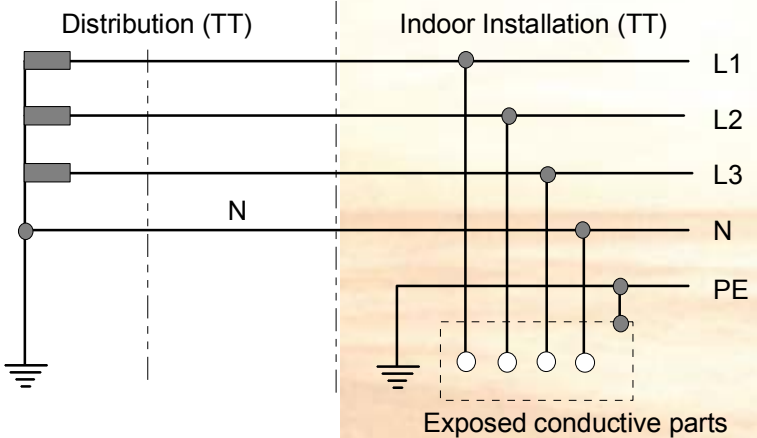
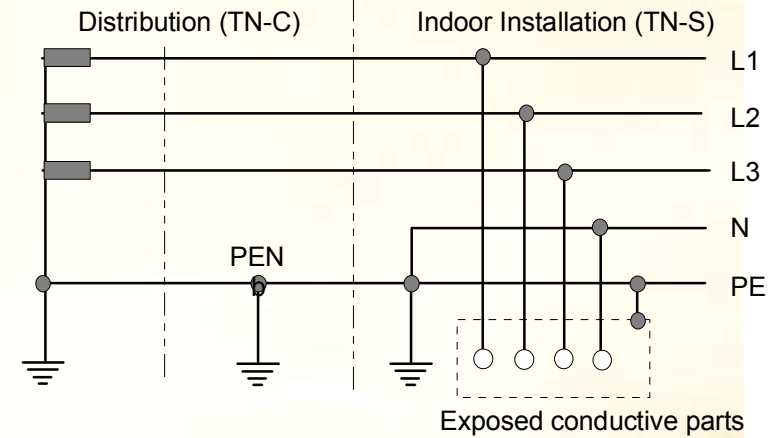
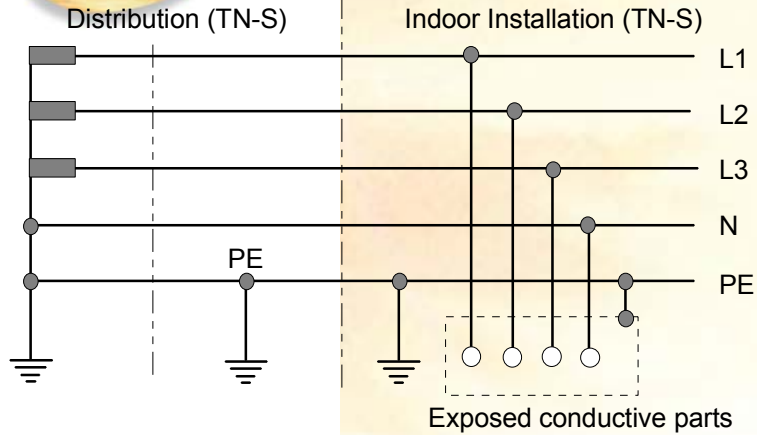



# Earthing systems and EMC

- **In differential mode:**

All earthing systems have equivalent phase-to-phase impedance (*source short-circuit power and cable lengths being equal*)

- **In common mode:**

For high frequency, unless equipotential bonding is used, all earthing systems are ineffective due to the cable length (cable impedance rises with the frequency).



# Earthing systems and EMC

	LF	HF
TT		risk of overvoltages in common mode
IT		strong risk of overvoltages in common mode
TN-C	Low Frequency currents through the PEN	High Frequency currents through the PEN strong risk of overvoltages in common mode
TN-S		

- **TN-C is to be banned in installation that includes electronic equipment**
- **TN-S is compulsory according to the EN 50174-2 and EN 50310 standards.**
- For high frequency, all earthing systems are "ineffective". Only good installation equipotential bonding can minimize such problems.
- In any case, surge arresters shall be used at cable penetration points, and as close as possible to sensitive equipment.



## Busways

- 50 Hz magnetic induction can disturb electronic systems and should be limited for the protection of people.
  
- The magnetic induction generated around a single-phase or 3-phase line depends on:
  - the level of current
  - the distance between conductors
  - the installation conditions (topology of cables)
  - the distance between measurement point and conductors
  - the metal enclosure shielding factor, when exists
  
- For equal currents, compact busways generate less induction than separate cables or conductors (about 3 to 20 times less, depending on the busways configuration).

# Cable Management System (raceways)

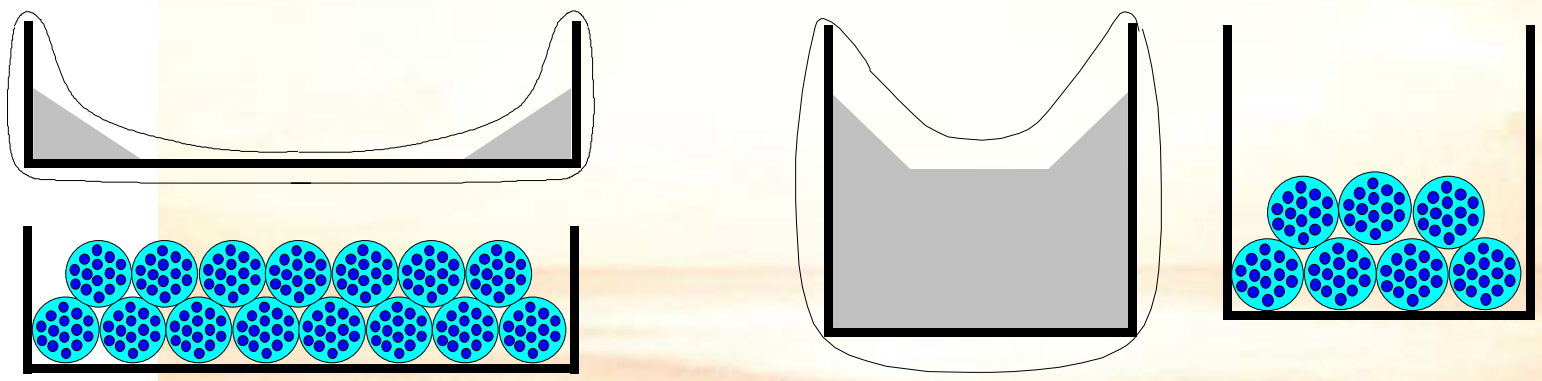
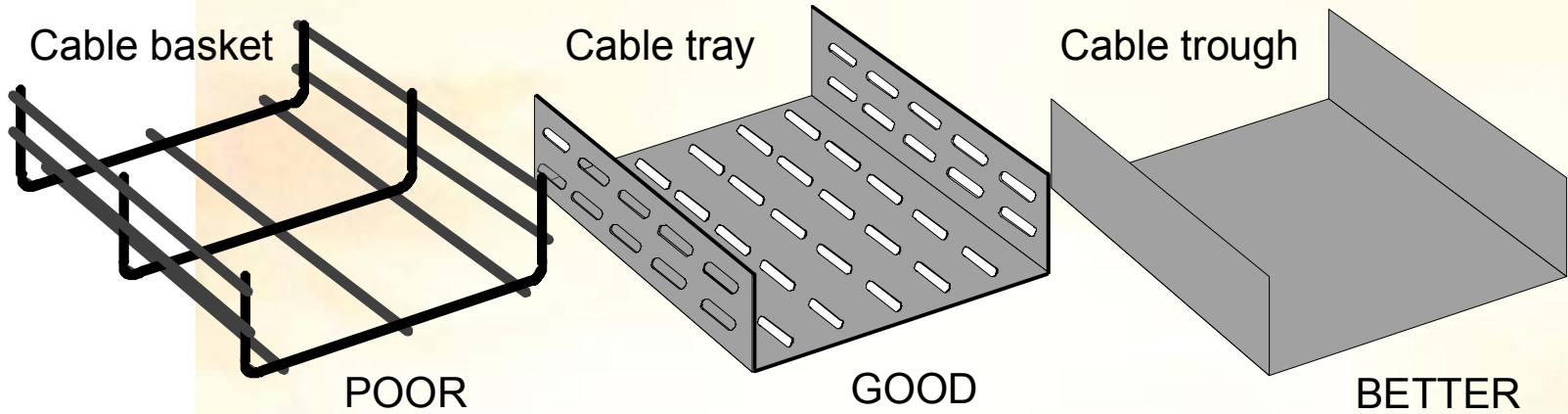

# Cabling classification

## ■ 4 distinct groups regarding EMC

- Group 4 : very sensitive
- Group 3 : sensitive to pulses, disturb the previous group
- Group 2 : not very sensitive, but disturb the previous groups
- Group 1 : disturb the previous groups

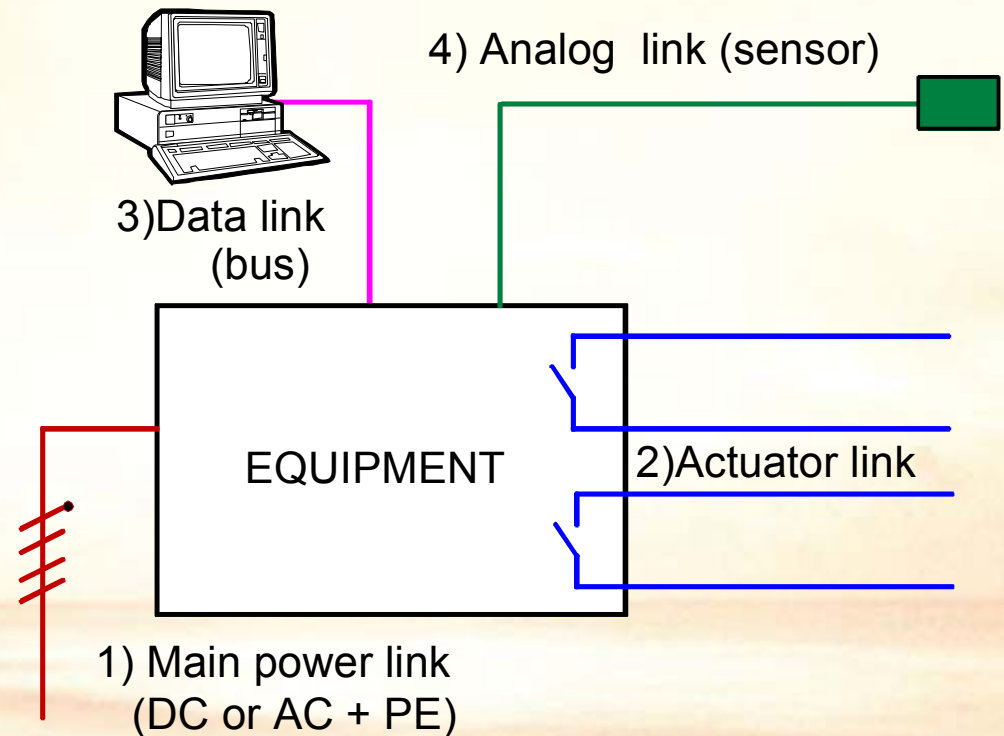







## Cable Management System (raceways)

- Metallic (unpainted) raceways shall comply with the following rules:
  - all raceways have folded edges
  - the cross-section meets requirements (plan ahead for center upgrading)
  - they shall be connected end-to-end and by overlapping of the 3 sides
  - they shall be grounded at both ends, at least, and at each intersection with other intersections, other raceways or metal parts
  - they shall be interconnected every 3 or 5 meters when they run parallel
  - they shall be bonded to the metallic structure of the devices served
  - a label indicates the kind of cables they contain
  
- Cable basket type raceways are reserved for optical fiber cabling or shielded cables if they are well bonded and are from the same “family”.

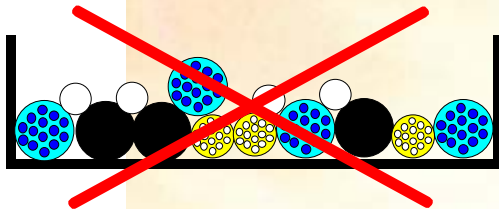
# Cabling management

**Not recommended**



-  Power cabling
-  Auxiliary circuits
-  IT cabling
-  Measure (very sensitive cabling)

**Correct**

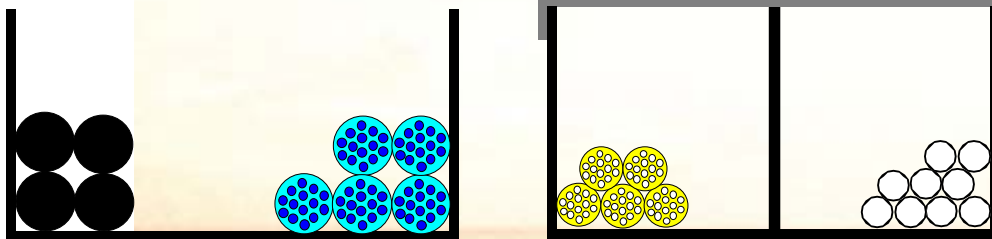

Metallic cable trays

Note :All the metallic parts are electrically well bonded

**Recommended**

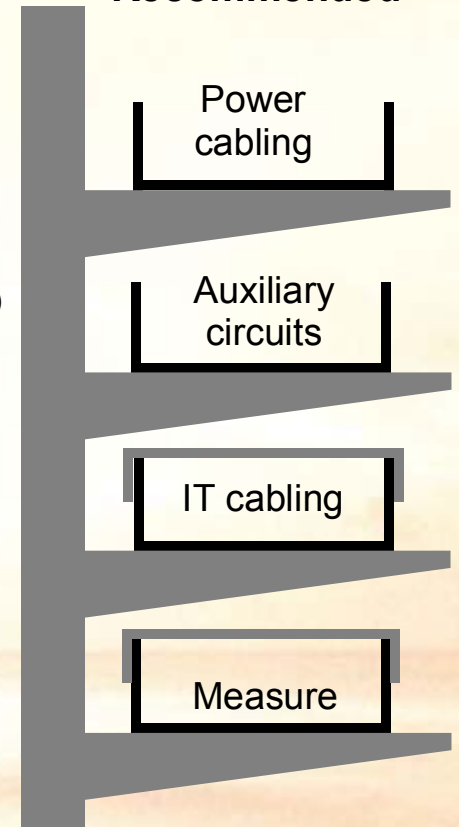



## How to connect the screen of a cable?

- If the 2 ends of the cable are parts of the same earthing zone, (except for the very low level isolated sensor cabling):
  - the screen is connected at both ends to the earthing and bonding system,
  - in case of 50 Hz noise, add a parallel earthing conductor ( $> 25 \text{ mm}^2$ ).
- For very low level isolated sensor cabling:
  - connect one end of the screen to the reference input of the sensor and the other end (electronic acquisition) to the ground point (chassis).
- If the 2 ends of the cable are not parts of the same earthing zone, the use of isolating components is required (transformers, optical, etc.) and both parts of the 2 isolated pieces of cable are connected to their common earthing system.



## Data cables and connectors

- The EN 50173 recommendations shall be followed regarding the choice of information technology cables
  
- The choice and implementation of connectors are as important as those of cables. The following points have to be followed:
  - cable shielding should be recovered around 360°
  - the connector should not downgrade the characteristics of the cable (symmetry, impedance, insulation, etc.)
  - follow the manufacturer's assembly recommendations
  - ensure grounding continuity by attaching the connectors correctly
  - comply with the cable's bending radius at the connector interface



## Surge Protective Devices (SPD's)

- SPD's are used for both electrical and IT protection.
- The design shall take into account different items (risk analysis)
  - surge probability vs. EM susceptibility of the equipment
- Efficiency of SPD's is closely linked to their implementation.
- Due to high speed and level currents ( $di/dt$ ), shortest connections are required to avoid extra over-voltages.
- Equipotential earthing and bonding systems serve lightning protection.
- SPD's shall be maintained (preventive).

# SPD's cabling

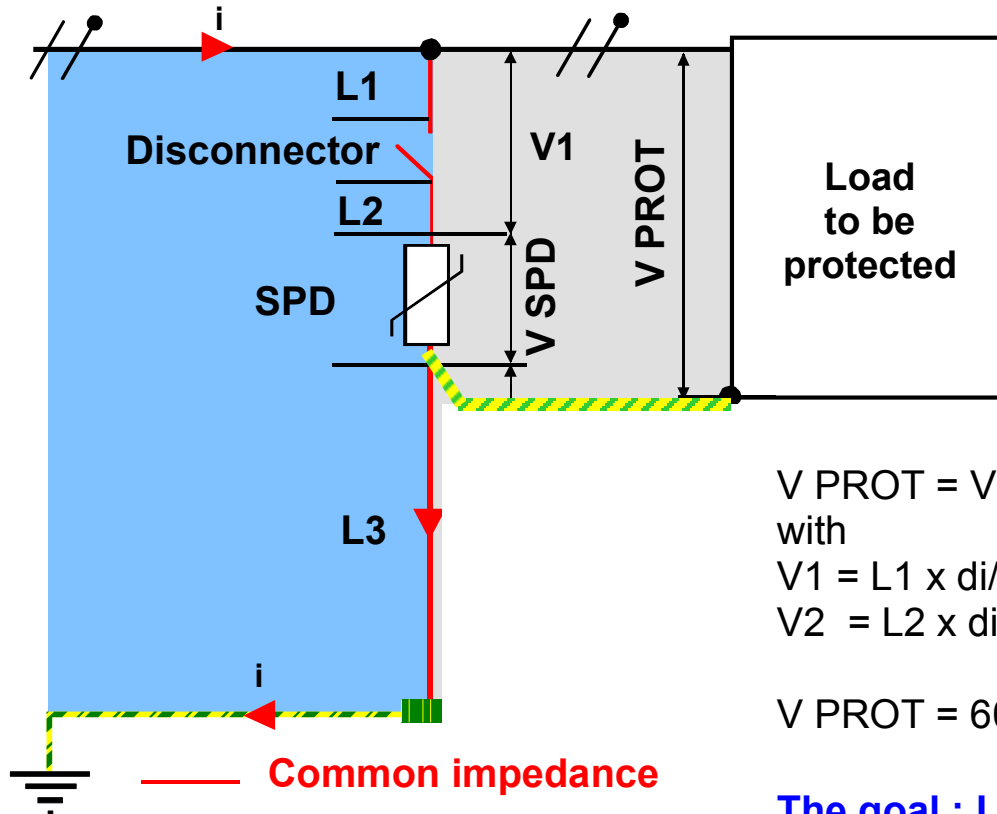

1 m of cable  $\approx 1 \mu\text{H}$

$di$  lightning = 10 kA

$L1 + L2 = 0,6 \text{ m} = 0,6 \mu\text{H}$

$L2 = 1,5 \text{ m} = 1,5 \mu\text{H}$

$dt = 10 \mu\text{s}$

$V_{SPD} = 1200 \text{ V}$

CM load voltage strength : **2000 V**

$$V_{PROT} = V_1 + V_2 + V_{SPD}$$

with

$$V_1 = L1 \times di/dt = 0,6 \mu\text{H} \times 10 \text{ kA} / 10 \mu\text{s} = 600 \text{ V}$$

$$V_2 = L2 \times di/dt = 1,5 \mu\text{H} \times 10 \text{ kA} / 10 \mu\text{s} = 1500 \text{ V}$$

$$V_{PROT} = 600 \text{ V} + 1500 \text{ V} + 1200 \text{ V} = \mathbf{3300 \text{ V} !!!!}$$

The goal :  $L1 + L2 + L3 \leq 0,6 \text{ m}$

In this case  $V_{PROT} < 1800 \text{ V}$

# Best practice SPD's cabling

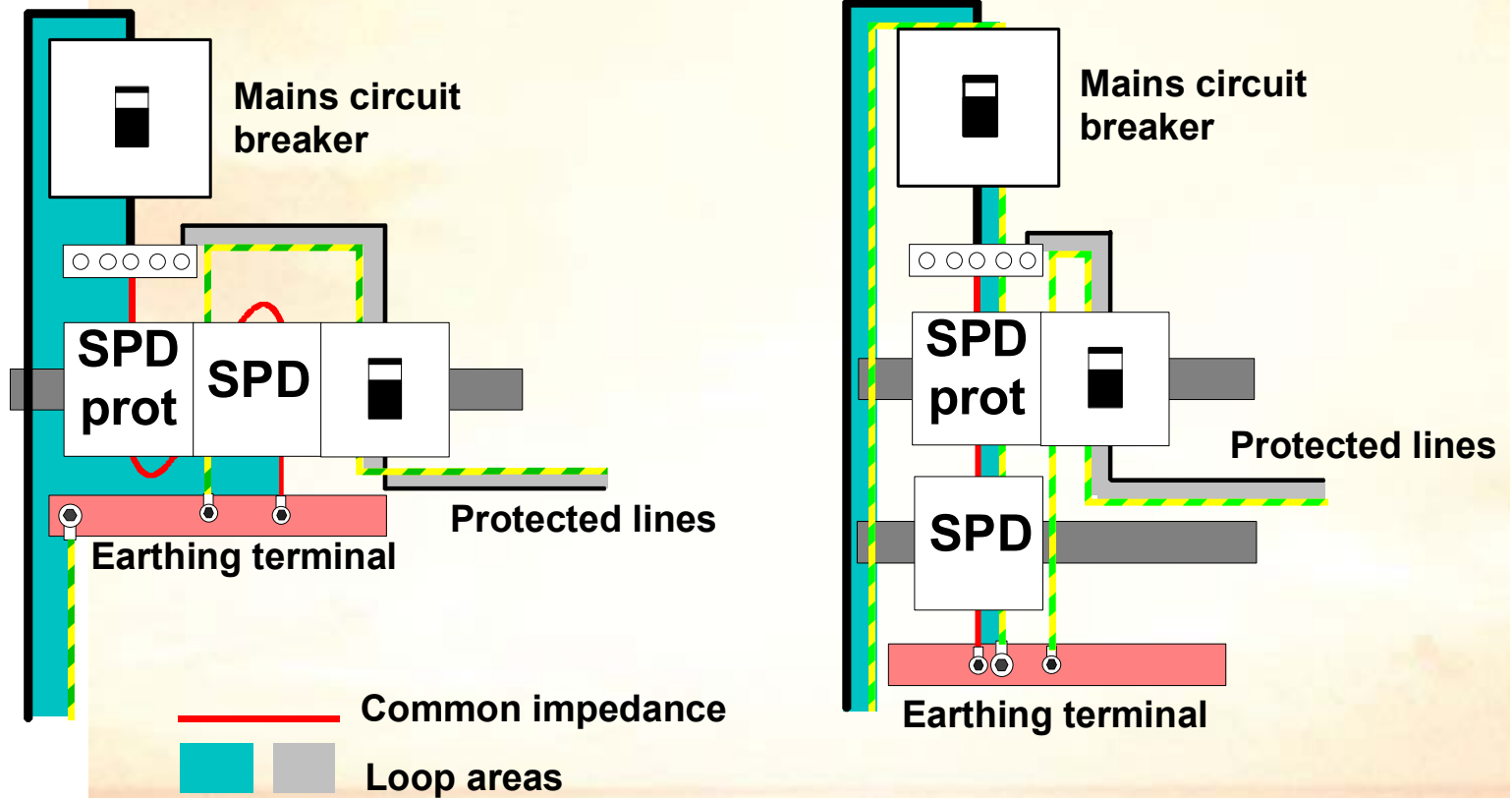

*Reduce the common impedance*  
*Reduce the loop areas*



# European Standardisation (Cenelec) dealing with installations

- Existing standards concerning installations (TC 215 Committee)
  - EN 50173 (Information Technologies generic cabling systems)
  - EN 50174 series (IT cabling installation)
  - EN 50310 (Application of equipotential bonding and earthing in buildings with IT equipment)
  
- Works in progress
  - EN 50173 and EN 50174 series are in revision
  - Different environments are now taken into account:  
office (commercial), industrial, residential premises, data centres



## EMC Expertise Services

- Assistance to EMC specifications and studies (standards, design, requirements, recommendations, etc.)
- EMC expertise on installations (analysis, diagnostics, remedies)
- Risk analysis (safety, dependability, availability) function of different environments
- Audit of installations
- Electromagnetic hardening for apparatus and installation
- Study for installation protection against lightning effects
- On-site EMC measurements
- EMC training



## EMC Expertise : Examples

- Support to design electrical networks (architecture, choice of earthing systems, organisation of the electrical distribution systems, choice of the protection systems and materials), in order to minimise EMC troubles (harmonics, transient surges, voltage drops, magnetic and electric field influence, electrostatic discharge, etc.)
- Facility audit and analysis of existing infrastructures (diagrams, equipment, cabling, etc.) with EMC measurements if required
- Audit and recommendations : how to install equipotential earthing and bonding networks, raised floors
- Design for the cabling management systems (separation between different kind of cable, cable routing, containment and raceways), to ensure a good immunity for the installed equipment.



## EMC Expertise : Examples

- Design for a global lightning protection (building infrastructure, electrical supply distribution, information technology cabling, control and monitoring cabling),
- Protection against low frequency magnetic field (50 Hz, DC) and high frequency electric field (broadcast, GSM, etc.),
- On-site measurements that can be used to :
  - identify potential disturbing sources or polluted areas,
  - check the coupling between different cabling,
  - have an “EMC reference”,
  - validate an installation (acceptance),
  - evaluate biologic risks regarding electromagnetic hazard.



## EMC Expertise experience

- Nuclear plants - Atomic centres
- Military - Aeronautical - Airports - Harbours
- Power plants - Hydroelectric power station - Wind farms
- Telecommunication - Broadcast stations - Data Centres - Banking & Insurance companies
- Chemical industry - Gas and petroleum production plants
- Metallurgical industry - Travelling cranes - Aluminium process
- Water & sewage treatment
- Railways - Subways - Tunnels
- Microelectronics industry
- Hospital - Medical centres
- Farm-produce
- Research centres - Universities